



BOAT LIFT DISTRIBUTORS INSTALLATION INSTRUCTIONS

Elevator Lift

Installation Instructions: Elevator Lift

Thank you for your recent Boat Lift purchase, it is important to note that this lift may be mounted to a dock piling, concrete seawall, or a concrete deck. The depth of water needs to be approximately 24" plus the draft of the watercraft. It is the contractor's responsibility to determine and construct suitable support fixtures and bracing for lift piling and/or seawall mounts. The Elevator Lift cannot be mounted to a freestanding piling as the piling may collapse. For tech support e-mail: gablinc@gmail.com

NOTE: The piling spread should be set no more or no less than the specification sheet for your lift's requirement.

STEP 1: PILING ADJUSTMENT

1. Cut the piling approximately 1' above the highest desired point of travel of the cradle.

Figure 1

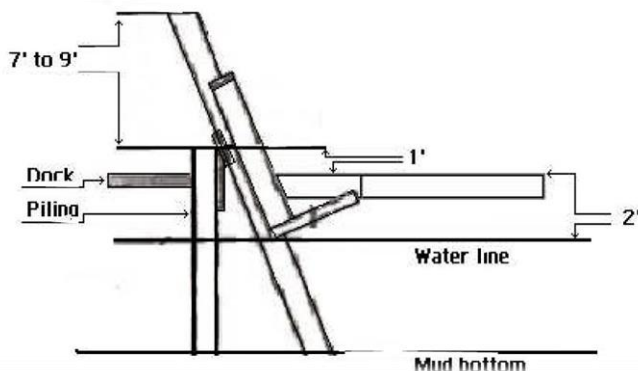

STEP 2: ATTACHMENT OF PILING MOUNTS

Thru-bolt the piling mounts to the top of the piling with three (3) 1/2" bolts or threaded rod. Leave a few inches of exposed piling above the mounting holes.

NOTE: It is recommended to shave the piling flat to prevent track twist.

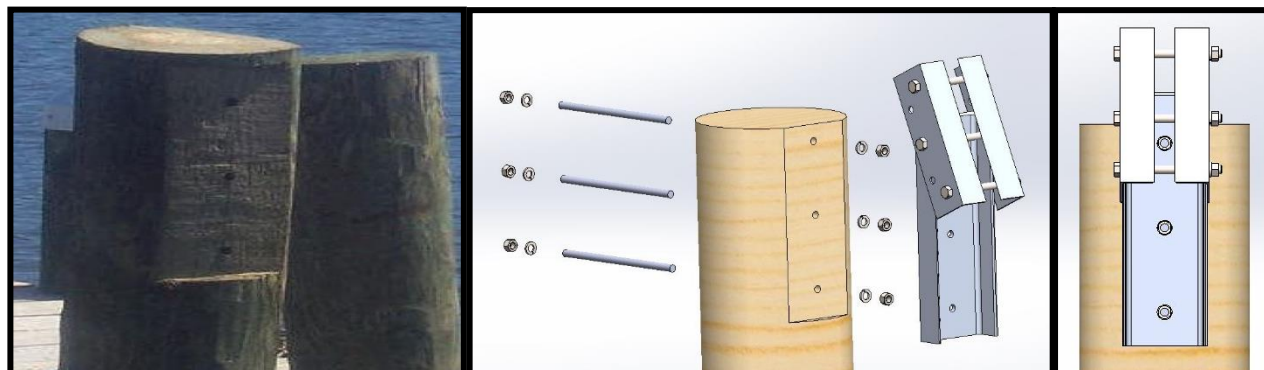

Shave piling to prevent track twist.

Exploded view of piling mount bracket and mounting hardware.

Assembled piling mount bracket

STEP 3: INSTALLING THE TRACK MOUNT

1. Confirm the holes used to mount the top units are facing the water.
2. Slide the track through the piling mount.

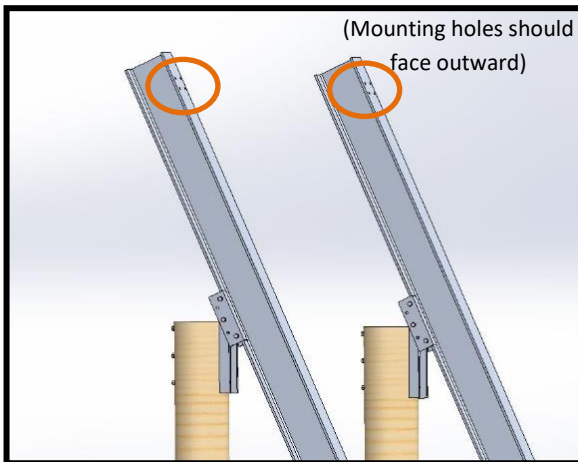

*10k, 24-degree angle lift shown



For **Angle Lifts** use an angle locator to guide the track into the ground or cut a 2" x10' or 2" x12' at 90 Degrees to put on the piling to help keep the angle of the track correct.

NOTE: For **Straight Lifts** use a level to guide the track into the ground.

STEP 4: SECURE THE TRACK

1. Secure the track into the ground with hammer or water jet.

NOTE: Confirm that the tracks stay at the degree the specifications recommend. **The track should be set according to your lift specification sheet.**

STEP 5: INSTALL CRADLE ARM ON TRACK

NOTE: To slide cradle arm onto the track, it is recommended that the installation be completed with the use of a barge or crane.

1. Place the cradle arm on the water side of the track.
2. Pull the cradle arm to the top of the track until the top rollers are higher than the track.
3. Pull the cradle arm back until top rollers are behind the water side of the track.
4. Lower the cradle arm onto the track.
5. Secure the cradle arm with a rope. This will keep the cradle from being pulled to the bottom.

**** Confirm that the top wheels are placed on the inside of the track, and that the bottom wheels are on the outside of the track (water side).**

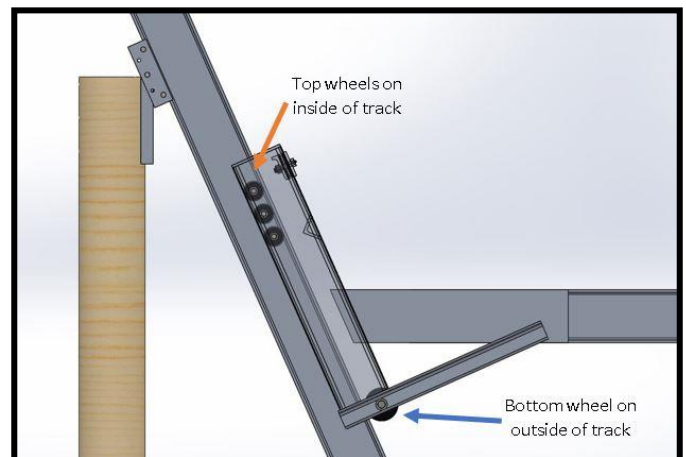

STEP 6: ATTACHMENT OF ELEVATOR TOP UNIT

Attach the elevator top unit to the top of the track using the hardware and five (5) of the mounting holes as shown below.

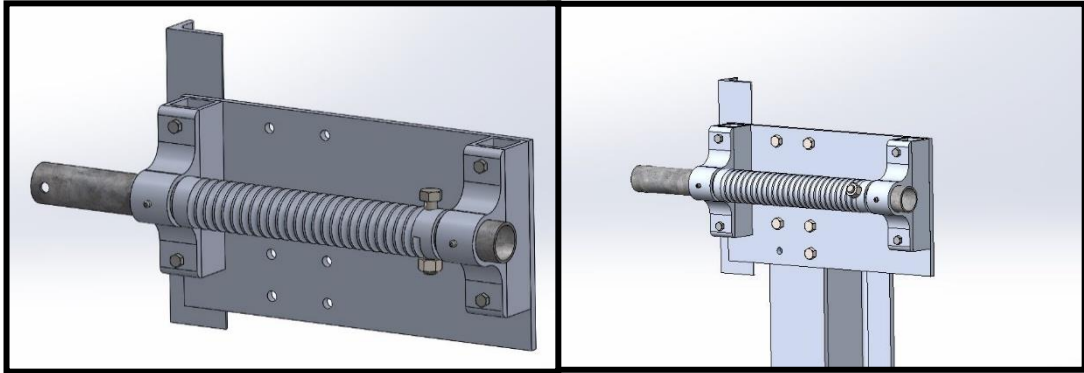

STEP 7: HEFTY HOIST MOTOR PLATE

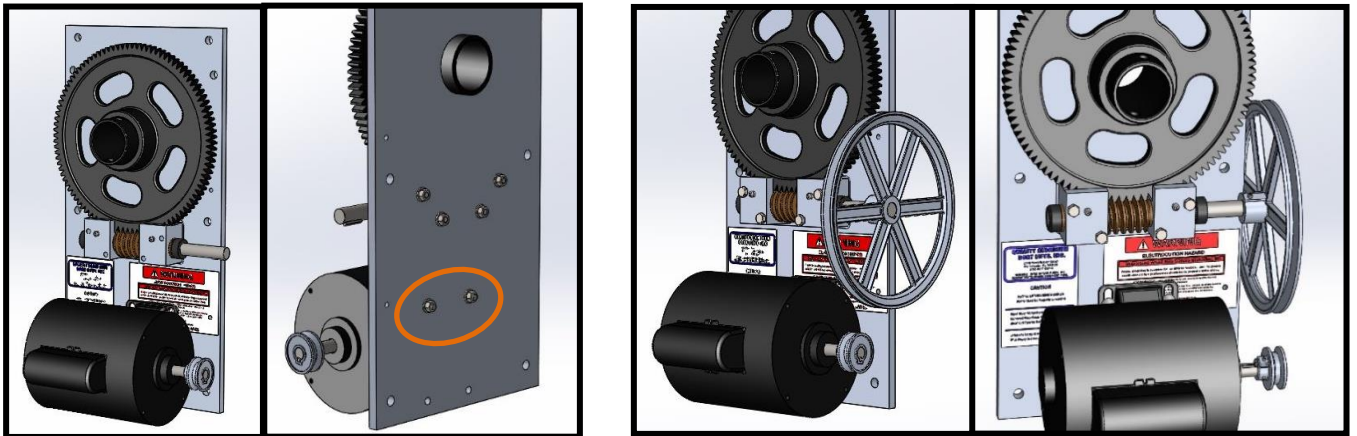

1. Attach the motor to the back plate using the upper two (2) mounting holes and provided carriage bolts.

2. Attach the 10" pulley to the hoist plate. Confirm the motor pulley and hoist pulley align.

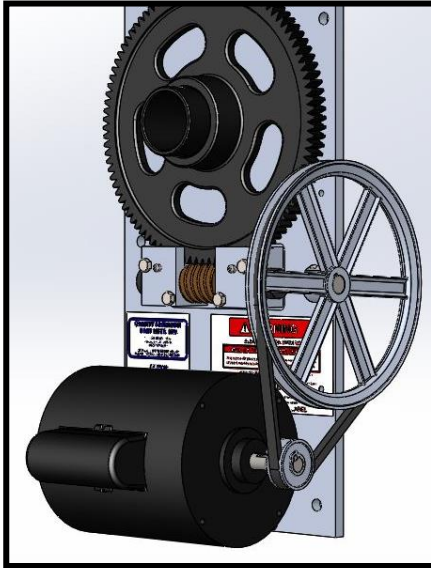

3. Attach the belt to the two pulleys. Confirm there is tension on the belt.

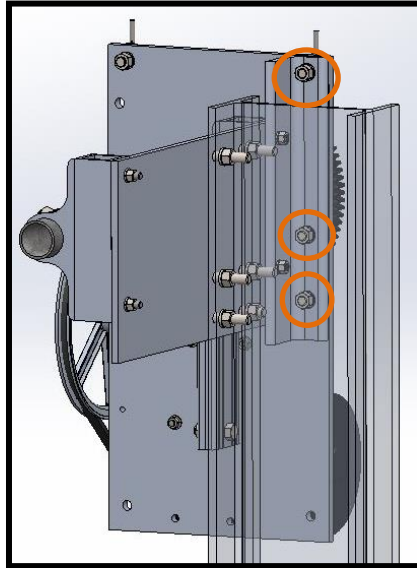

4. Attach the top left washer by mounting the drive unit to the top unit using the top left hole. Secure the drive unit to the top unit using the other two holes shown above.

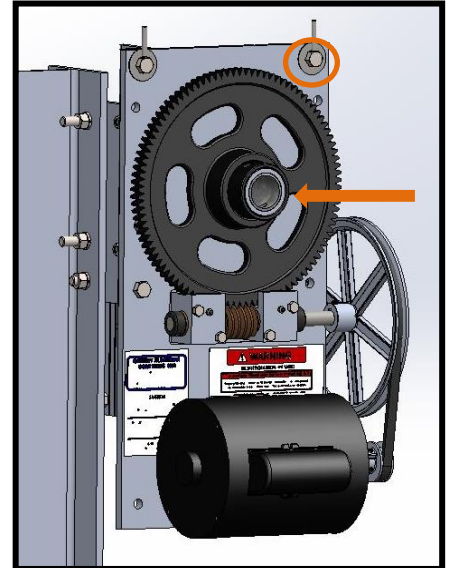

5. Attach the top right washer to the drive unit plate. Slide the aluminum motor spacer between the drive pipe and the drive unit gear. This will take the play out of the hoist and the drive pipe.

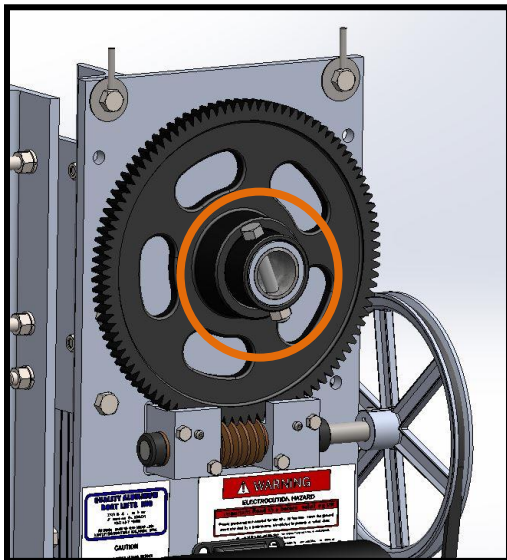

6. Secure the motor spacer with the 1/2" x 3-1/2" gear bolt and 1/2" lock nut provided with the hoist.
IMPORTANT: Do not use a Stainless Bolt if the Bolt is missing.

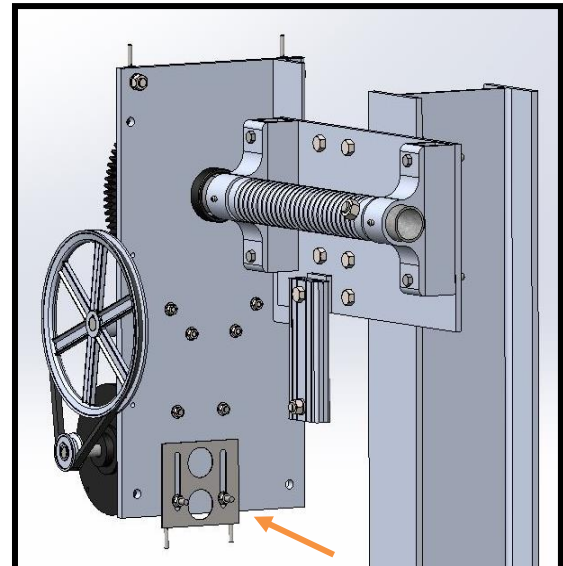

7. Attach the bottom sliding plate using two carriage bolts through the bottom motor mounting holes.

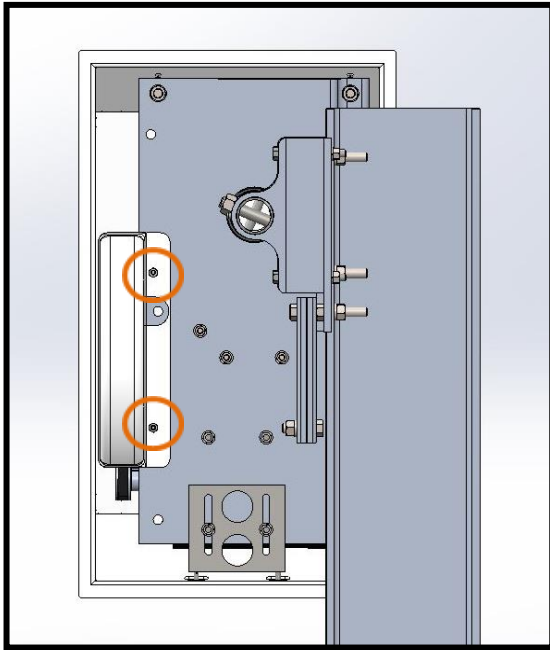

8. Install the half-moon cover over the 10" pulley using the two holes shown above.

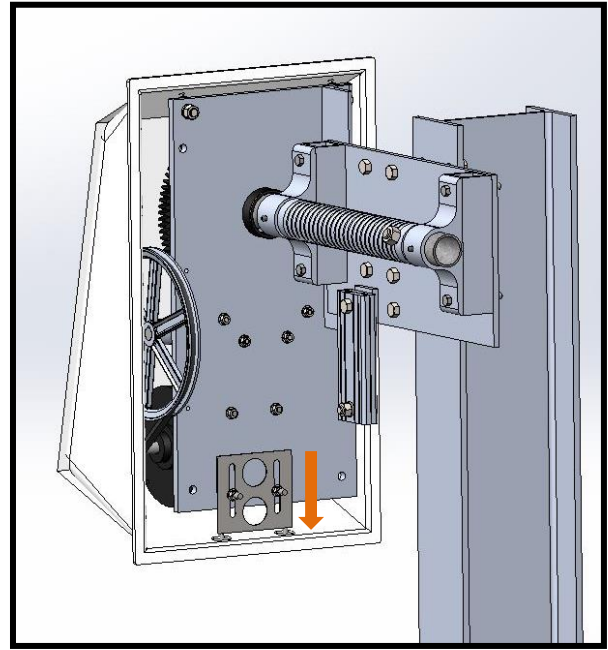

9. Put the cover on over the top washer pins and pivot the cover until the bottom holes are in line with the bottom sliding plate. Slide the bottom plate down until the pins fit through the bottom holes in the cover and tighten the plate hardware to secure in place.

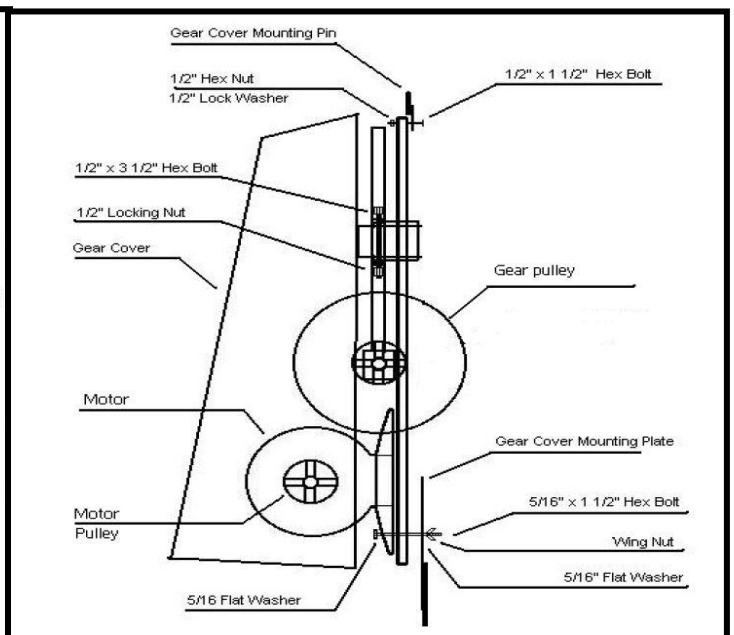
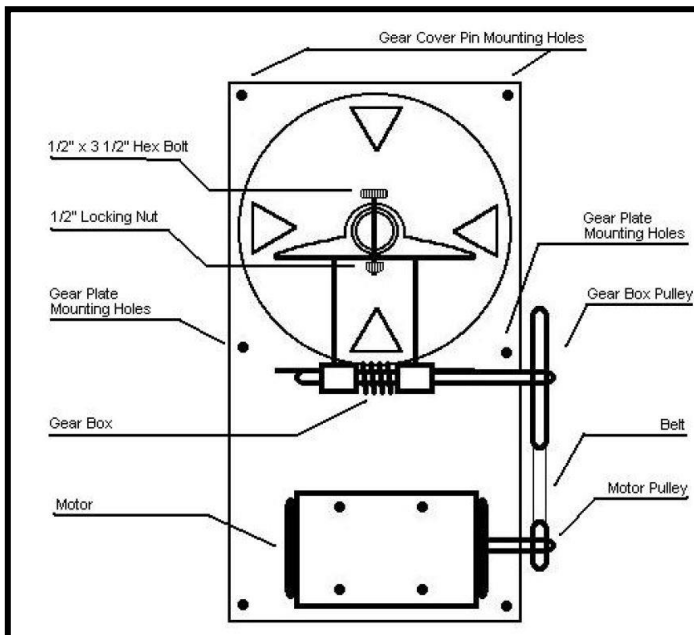

Flat plate drive diagrams

STEP 8: CABLE INSTALLATION

Adjustable Deadman Bracket

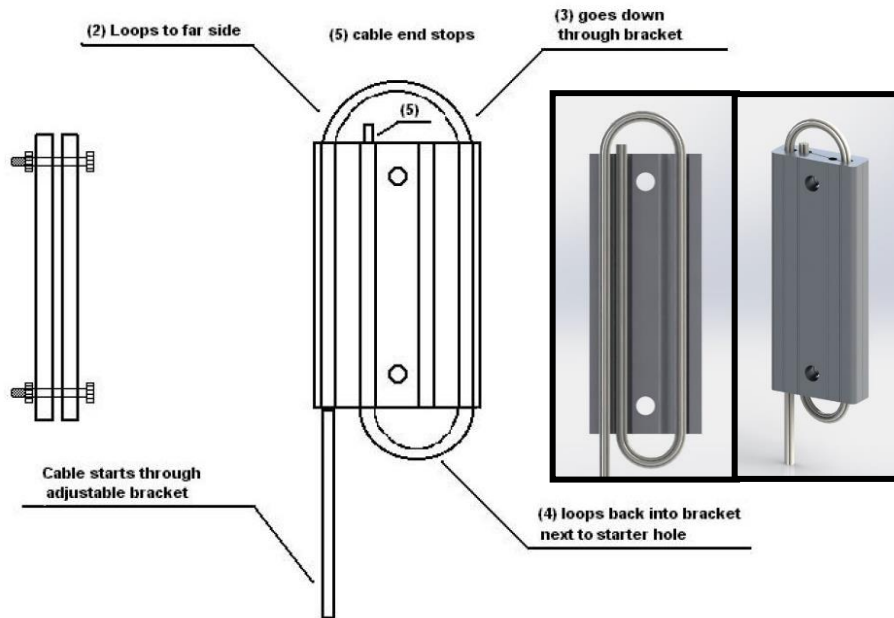

1. Make sure one end of each cable is installed in the deadman bracket as shown.

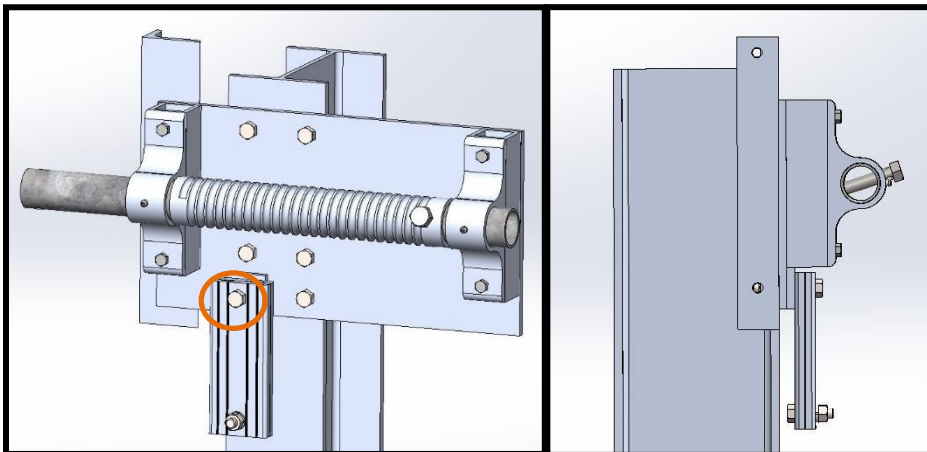

2. Attach the deadman bracket to the track to using the bottom left hole of the top unit.

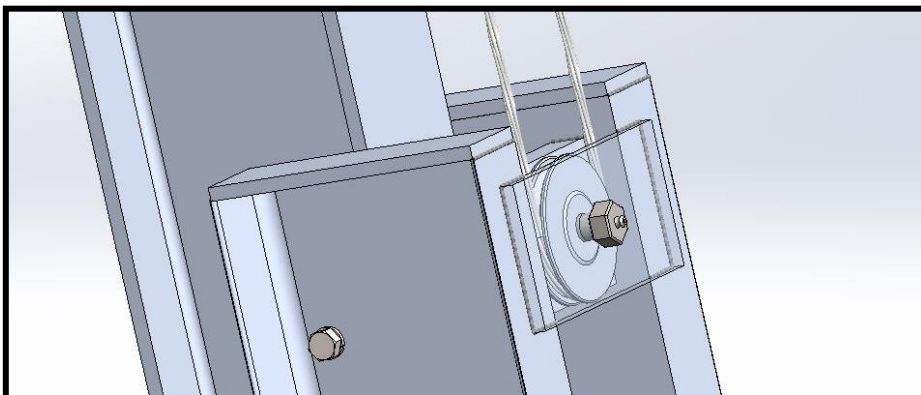

3. Take the free end of the cable and wrap it around the pulley in the top of the cradle arm. Bring the end back up to the cable winder.

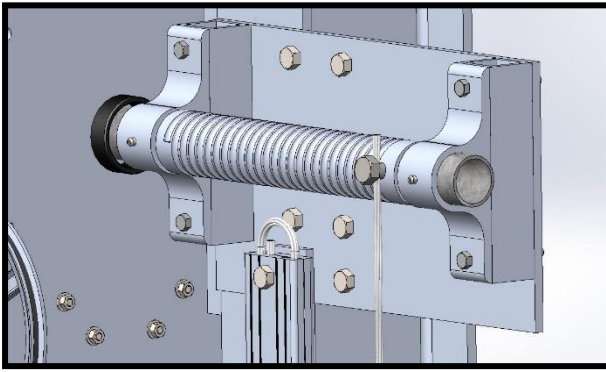

4. Insert one end of the cable through the cable bolt hole and tighten the cable bolt until the cable is securely clamped to the cable winder.

STEP 9: HARDWIRING OF DRIVE UNIT

1. Complete the hard wire of the drive unit, otherwise plug the drive unit into the power supply.
(Gem remote diagrams are included in a separate file)

STEP 10: WINDING OF CABLE ON CABLE WINDER

1. Wind up the cable onto the cable winder; Turn the switch to the up position. Confirm that the cable is wrapping on the outside (**OPEN SIDE**) of the cable winder.
NOTE: If either of the cables is winding on the wrong side of the cable winder when the switch is turned to the up position, the switch wires on T8 & T9 will need to be switched inside of the switch.
IMPORTANT: SHUT OFF ALL POWER BEFORE OPENING THE SWITCH BOX.
2. **IMPORTANT: (WEAR GLOVES).** Continue to roll the cable onto the cable winder. Be sure to hold tension on the cable as it rolls onto the cable winder until the cable starts to pull the cradle arms up the track.
3. Level the cradle arms.

STEP 11: CROSS BRACING INSTALLATION

NOTE: Use the specification sheet to determine how many cross braces the specific lift will require.

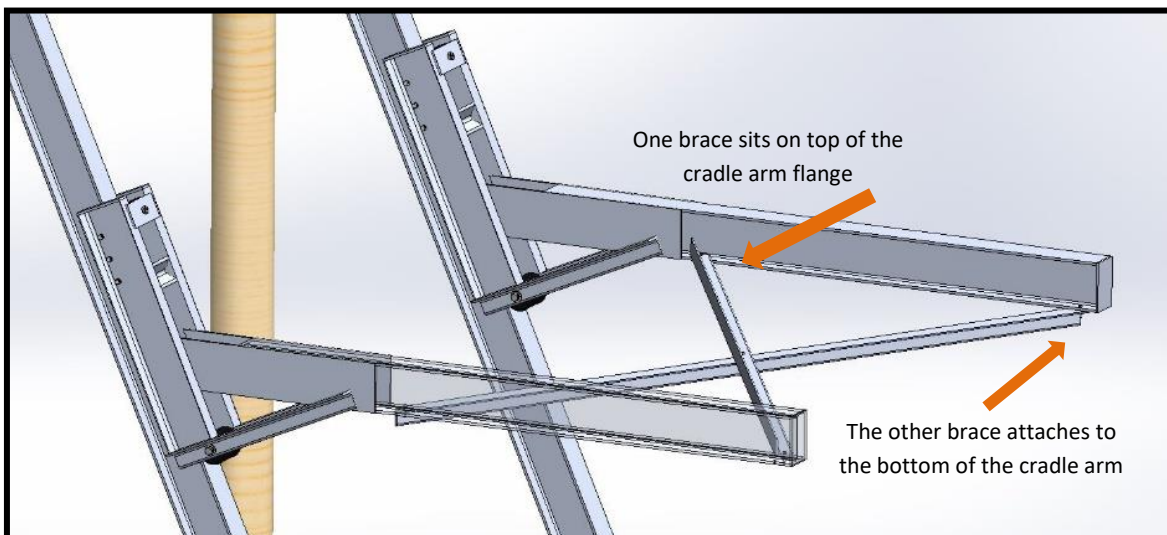

1. Confirm that the placement of the cradle arms is level & square.
2. Attach one (1) of the braces to the bottom of the cradle arm closest to the shore.
3. Attach the opposite side of the cross arm to the bottom farthest from the shore.
4. Attach the next cross brace on top of the flange on the bottom of the cradle arm farthest from shore.

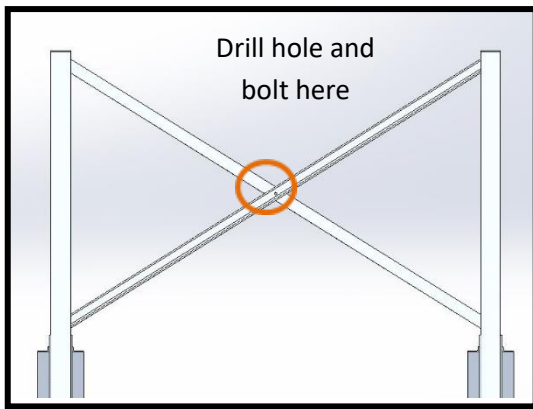

5. Confirm that the cradle is square.
6. Drill a hole in the middle where the two (2) cross braces meet.
7. Attach a bolt in the middle to secure the two braces.

STEP 12: GUIDEPOST BRACKET INSTALLATION

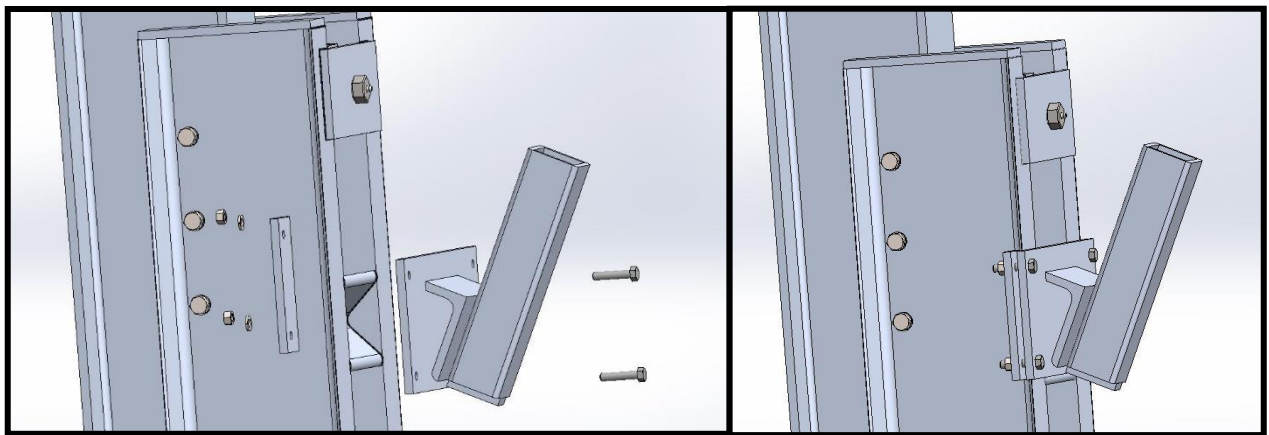

Mount the guidepost bracket to the front of each cradle arm using the aluminum plates and hardware as shown.

STEP 13: WEIGHT PIPE AND GUIDEPOST INSTALLATION

1. Slide the weight pipes into the tops of each guidepost bracket.
2. Slide the PVC guideposts over the weight pipes

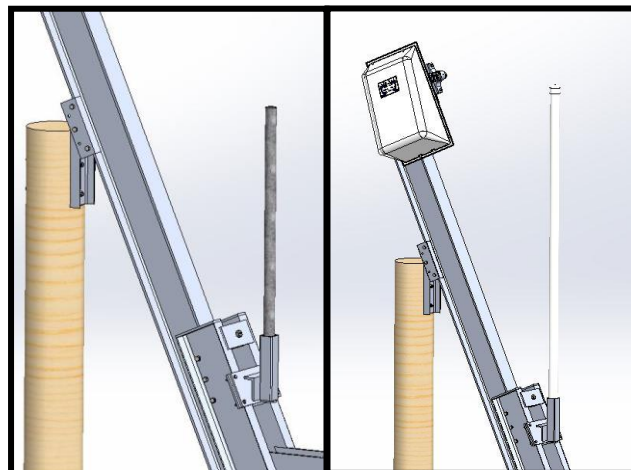

STEP 14: ATTACHMENT OF BUNK BRACKETS TO CRADLE ARMS

1. Measure the width of the boat.
 2. Measure from the outside of the guidepost toward the outside of the cradle arm and mark the location of the center of the boat on the cradle arm.
 3. Take the eight aluminum brackets (4 sets) and attach each pair to the cradle arm with two stainless steel bolts. One bolt will rest on top of the cradle arm; One bolt will hang under the cradle arm
 4. Mount each of the bunk brackets 12" to 16" away from the center mark.
- NOTE:** Bunk Spreads do sometimes vary 12" to 14" for boats up to 9000lbs. Larger boats can go up to 16".

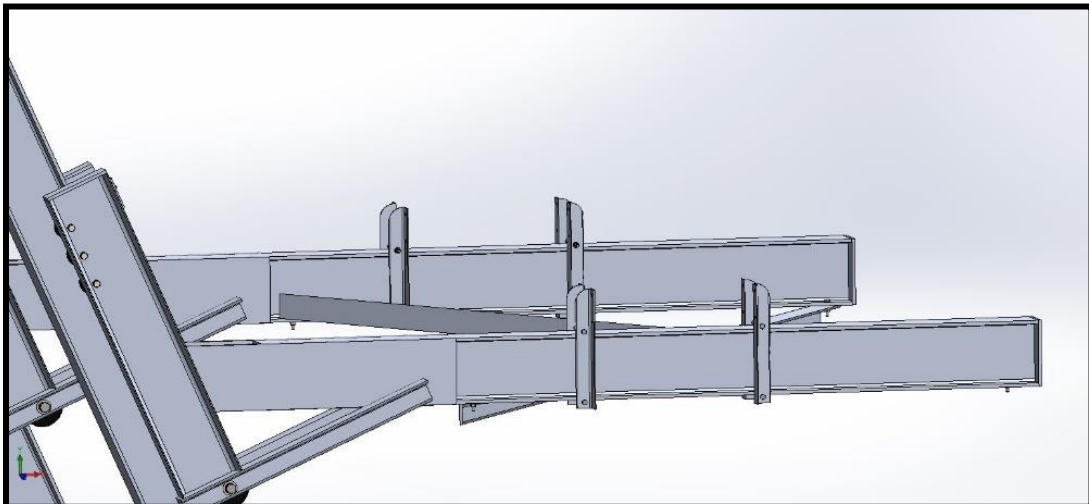
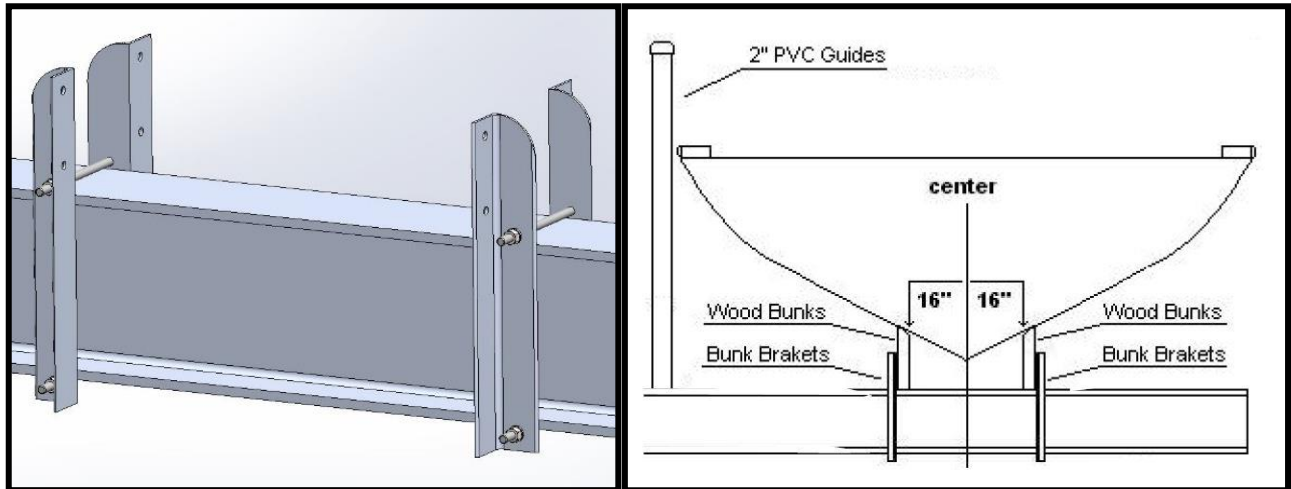

STEP 15: ATTACHMENT OF BUNKS TO THE BUNK BRACKETS

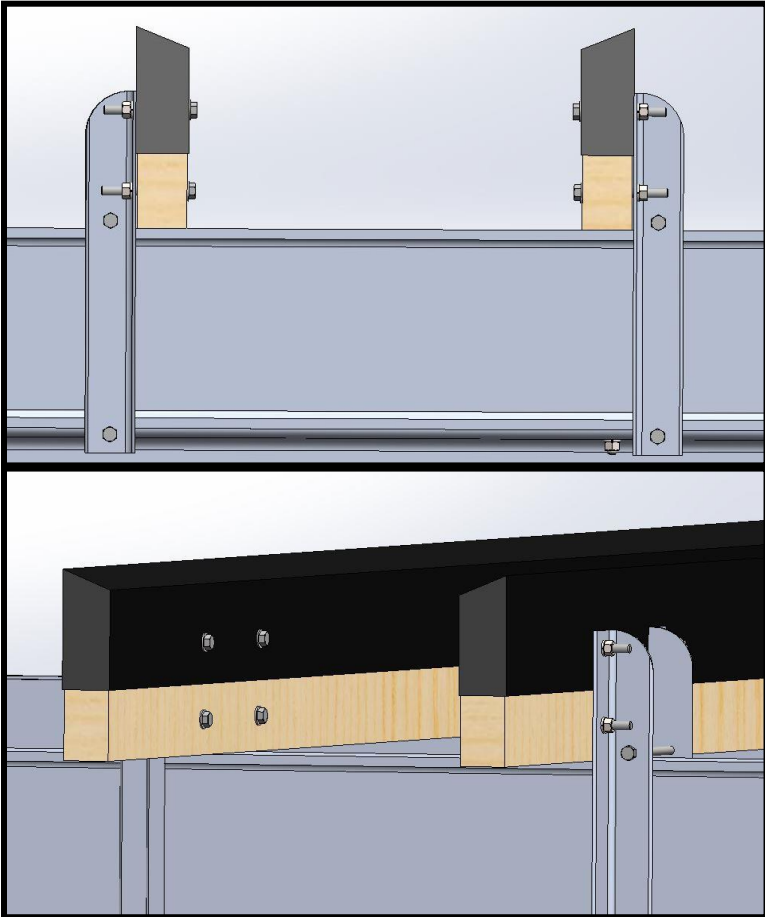

1. Confirm that the cradle arms are level and square.
2. Place the bunks on the inside of the bunk brackets.
3. With the cradles square, measure out the distance between the cradle arms and center the bunks between them. The bunks should overhang equally on each side of the cradle.
4. Confirm again that the cradle arms are level and square.
5. Mark the bunk bracket hole location on the bunks.
6. Drill eight, 3/8" holes (four holes on each end of the bunk) where the bunks will be mounted to the bunk brackets.
7. Install the bunks with the provided hardware. Tighten all hardware.

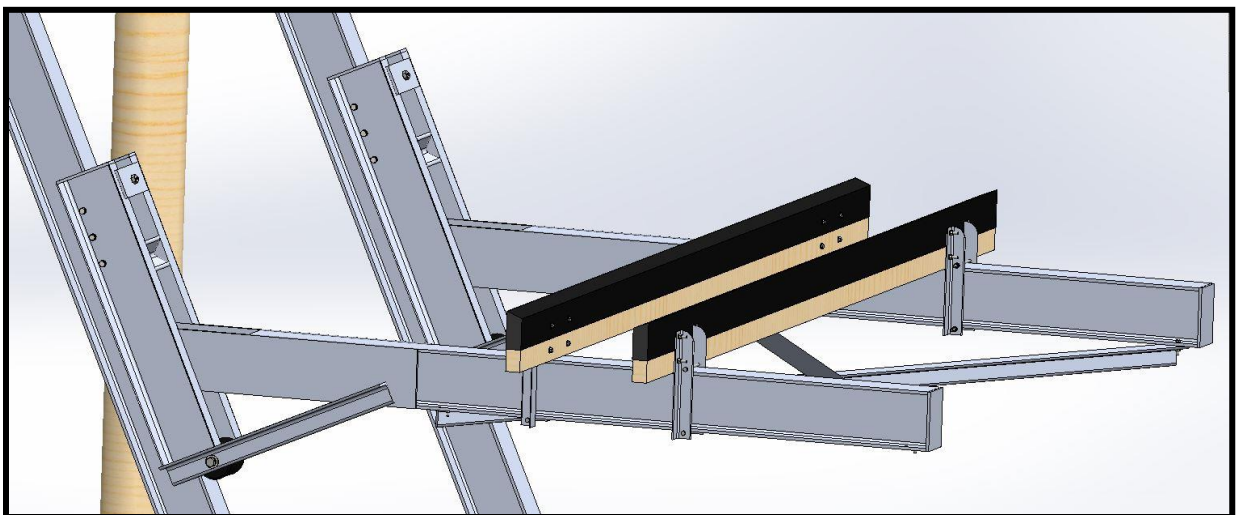

Complete Installation:

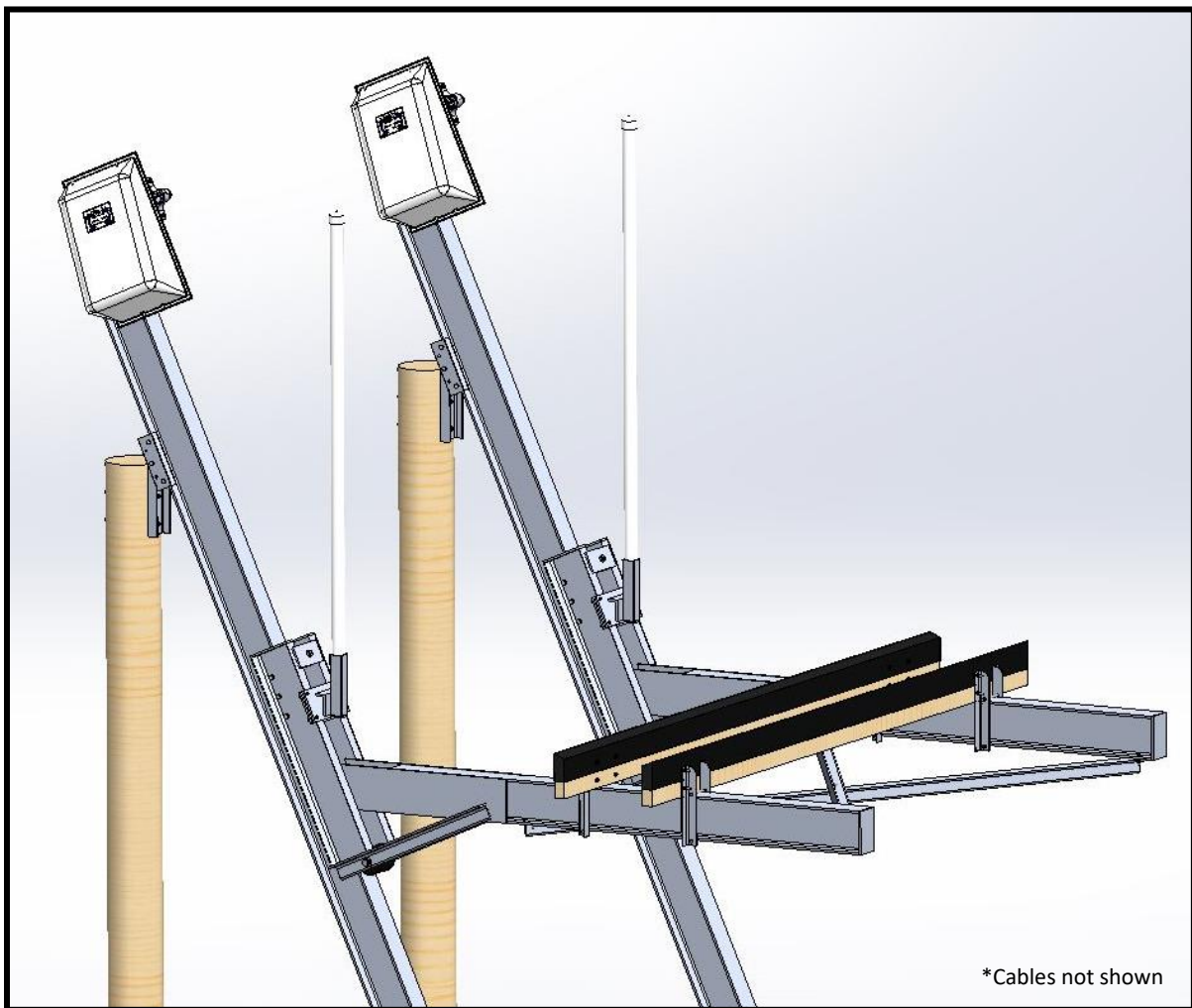

FITTING BOAT TO LIFT:

1. Bunk Adjustment: loosen the eight (8) bunk brackets. Mark center line port to starboard on both cradle beams. The bunk spread varies; for boats up to 9,000lbs. (26' to 28' range). Spread bunks 32" apart; 16" from center lines on cradle beams.
2. Place boat into position for lifting. Guide poles will keep boat centered over bunks. It is very rare to have more than three (3) feet of boat hanging beyond the stern lift pilings. The center boat balance needs to be as close as possible to center of lift (Bow to Stern). this will evenly distribute the load over the two (2) cradle beams. **The Bow and Stern Cable Tension will be equal with a balanced load.**
3. Lifting of the Boat Adjustment: Start lifting the boat, if the boat starts leaning as you pick it up you will have to readjust the pickup bunks and lift the boat again. If the boat does not lean, do a visual inspection of hull and bunk contact. The following are necessary for proper bunting. The keel of the boat should **NOT** be touching the cradle beams, if making contact with the cradle beam(s) you will need to move the wood bunks closer together.
4. Confirm the pickup bunks are not resting against any thru-hull accessories; water, intakes or transducers, etc.
5. Confirm that the cradle beams and boat is level.

HELPFUL NOTES:

1. To reverse the motor direction, change T-8 & T-9 in the switch.
2. Your gem remote wiring diagrams are located inside the remote.
3. Stickers on the cradle arms should face the outside. (Away from each other)
4. Place a rubber mat between top of piling and aluminum to prevent electrolysis.
5. Installer is responsible for determining that pilings are square and adequate to carry the lifts payload.
6. **Warning:** any modification to lift voids the warranty.
7. **Caution:** boatlifts are not made for lifting humans.